

40-60GHz Full U Band Low Noise Amplifier

High Gain=33dB, NF=6dB



Product Overview

AT-LNA-4060-3306VC is Low Noise Amplifier with 6dB Noise Figure in the frequency of 40-60GHz. The DC power requirement is +5V/220mA. The module is with 1.85mm Female

AT Microwave can provide all kinds of coaxial low noise amplifiers, with frequency from 0.01-67GHz, gain from 20 to 60dB, Pout from +5 to +27dBm, and connectors from SMA to 1.85mm.

More information, please visit www.atmicrowave.com

Advantages

- ✓ Frequency: 40-60GHz
- ✓ Small signal gain: 33dB
- ✓ Noise Figure 6dB
- ✓ Single Power Supply

Application

- ✓ U Band Communication
- ✓ Test Equipment
- ✓ ROF (RF Over Fiber)
- ✓ Radar System

Key Features

Parameter	Min	Typical	Max
Frequency		40-60GHz	
Gain	30dB	33dB	
Gain Flatness		+/-3dB	+/-5dB
NF		6dB	7dB
P1dB		+10dBm	
Psat	+10dBm	+12dBm	
Drain Supply		+5V	+8V
Current		220 mA	280mA
Input Return Loss		-7 dB	
Output Return Loss		-7 dB	
Spec Temp		25C	





AT-LNA-4060-3306VC

40-60GHz Low Noise Amplifier

Mechanical Information

Item	Description
Input Port	1.85mm Female
Output Port	1.85mm Female
Case Material	Copper
Package Sealing	Epoxy Sealed
Finish	Gold Plated
Weight (Without Heatsink)	50g
Size:	30x30x14 mm

Absolute Maximum Ratings Table

Parameter	Value
Drain Supply	+13V
RF Input Power	+10dBm
Operating Temperature(note)	-20 to +70C
Storage Temperature	-65 to +150C

Note: -40 to +85C is available according to request.

Notes:

1. Datasheet may be changed according to update of MMIC, Raw materials , process, and so on.
2. This data is only for reference, not for guaranteed specifications.
3. Please contact AT Microwave team to make sure you have the most current data.

Part Number Selection Guide

Item	Description
PN	Stand Module with DC Power Supply
PN-LCBT	L ow Cost, C ompact B ench- T op, +220V Supply with AC/DC Adapter



Test Data:

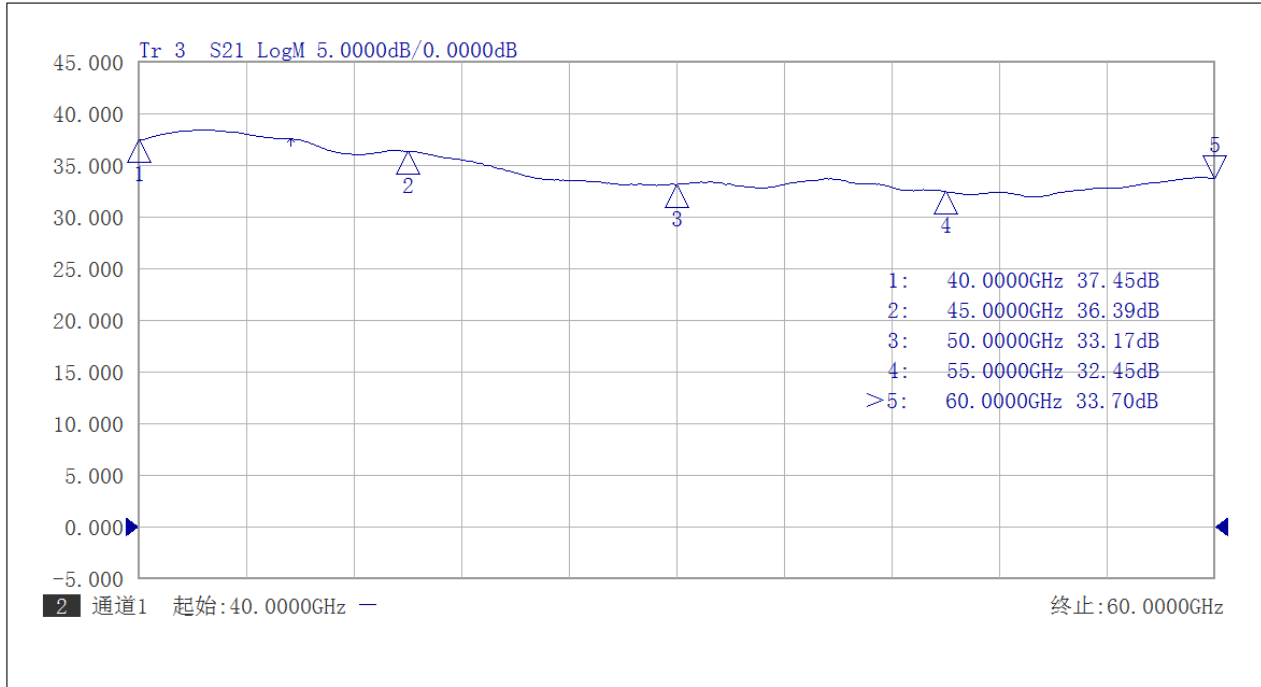

Gain vs Frequency

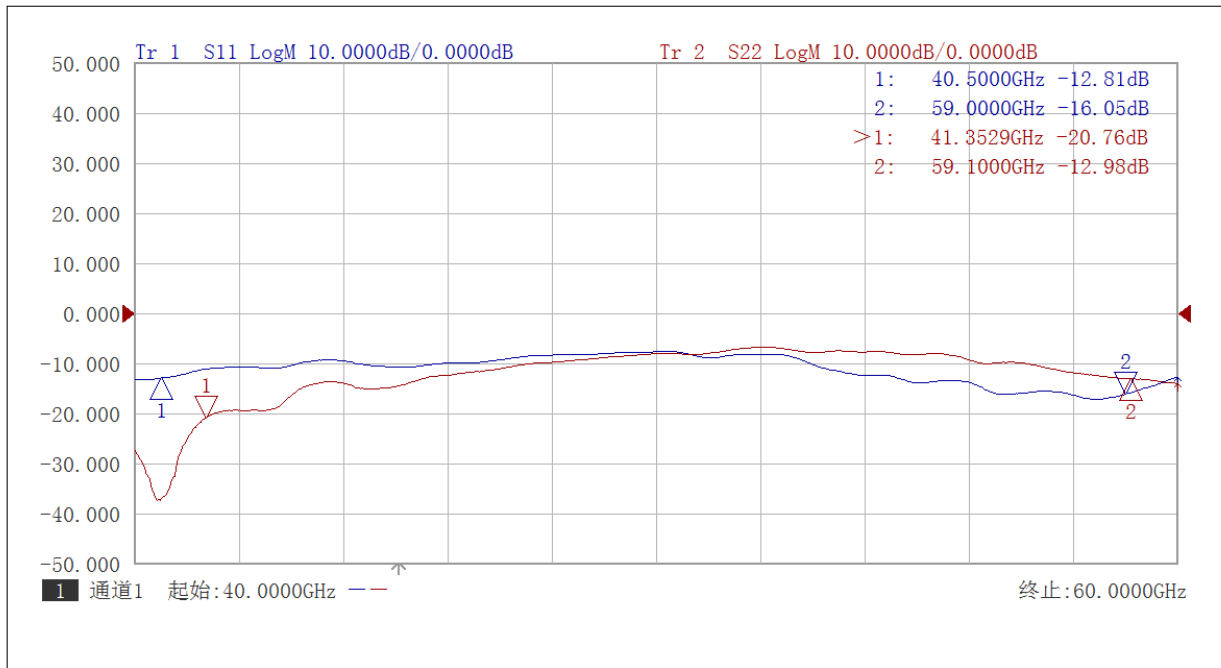

Input and Output Return Loss



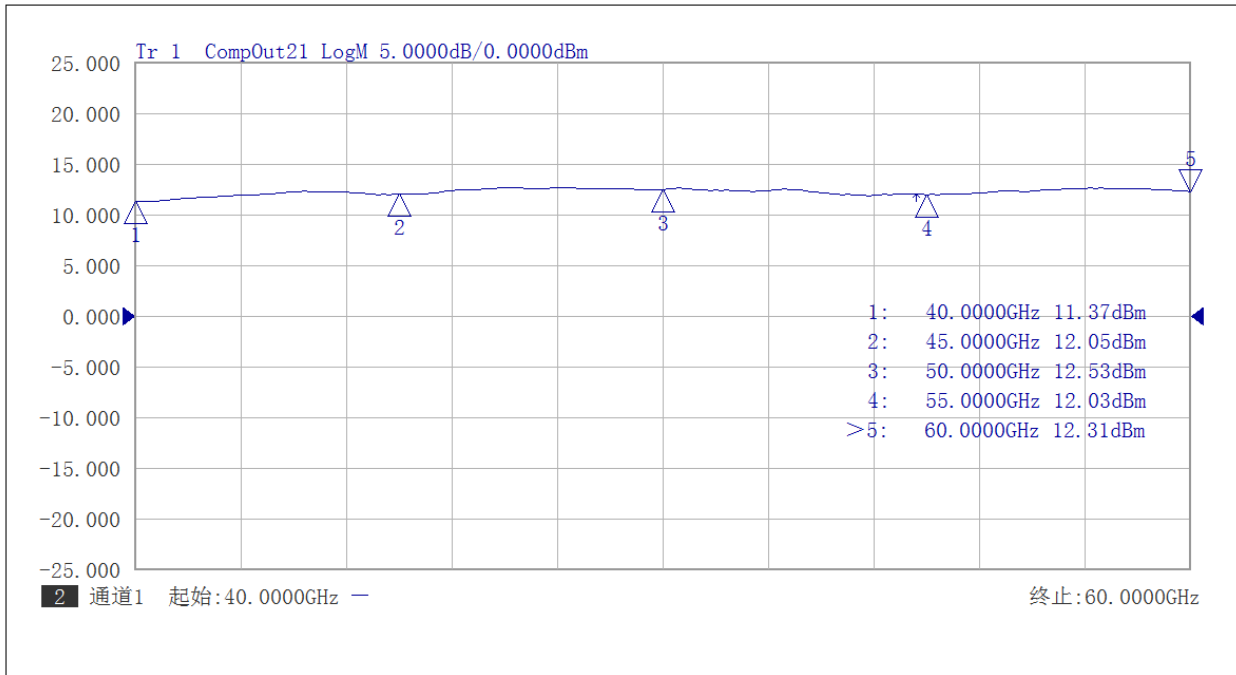

P1dB vs Frequency

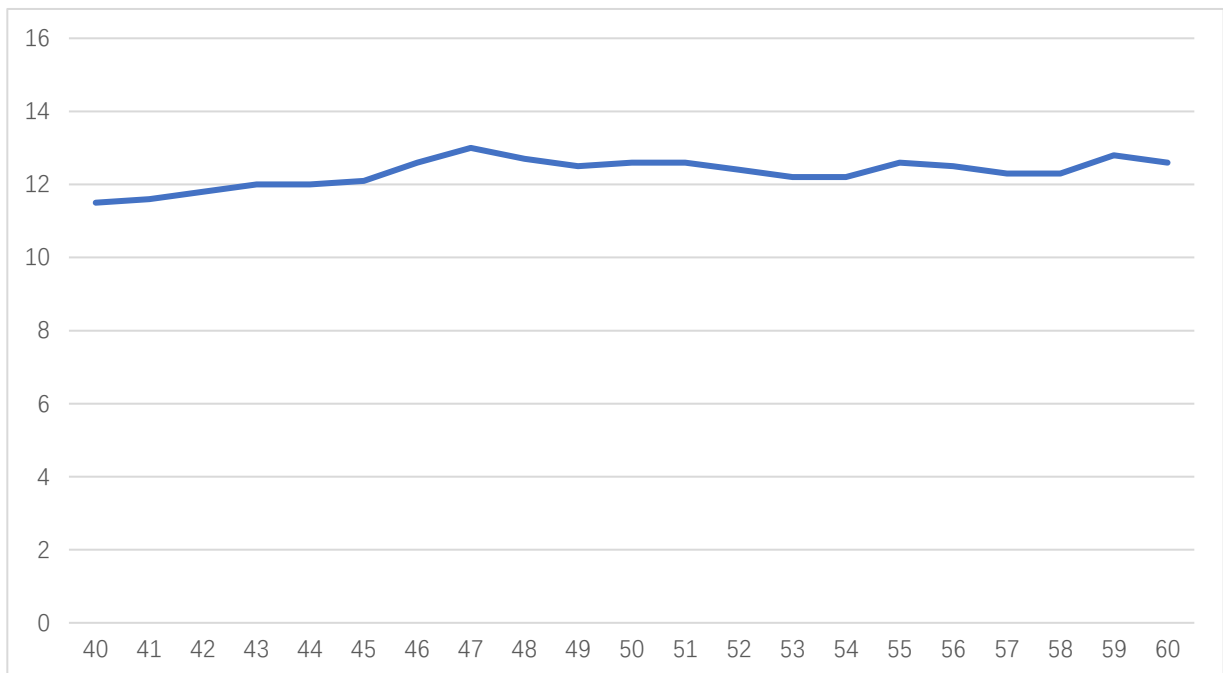

Psat vs Frequency



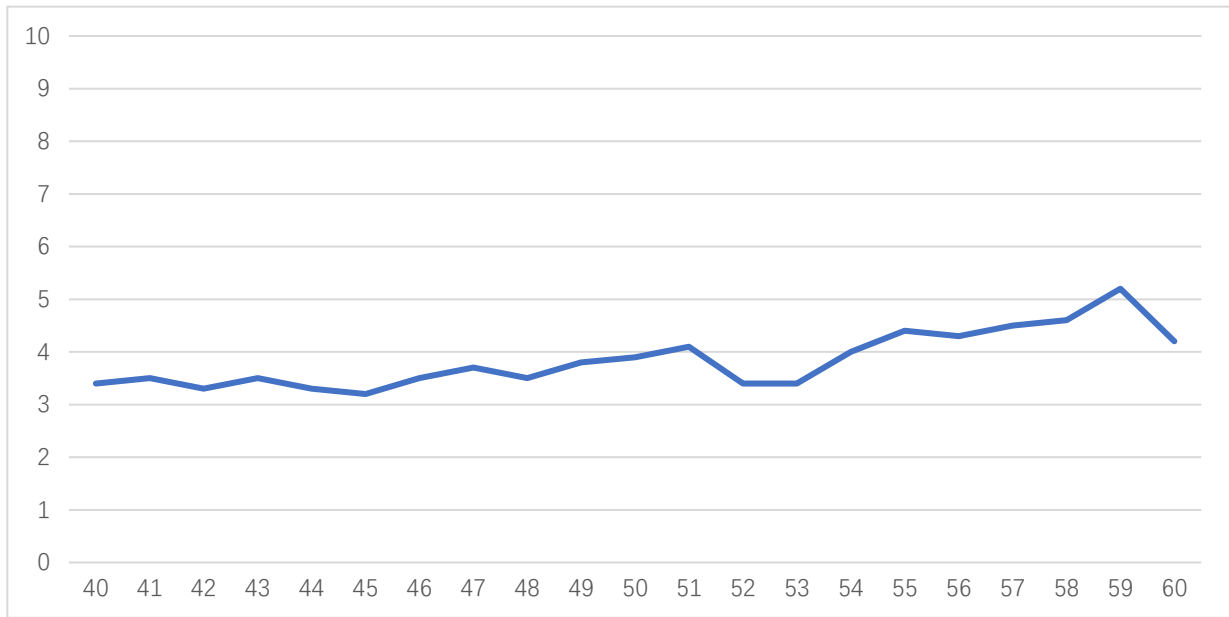

NF vs Frequency

Dimension: (unit in mm)

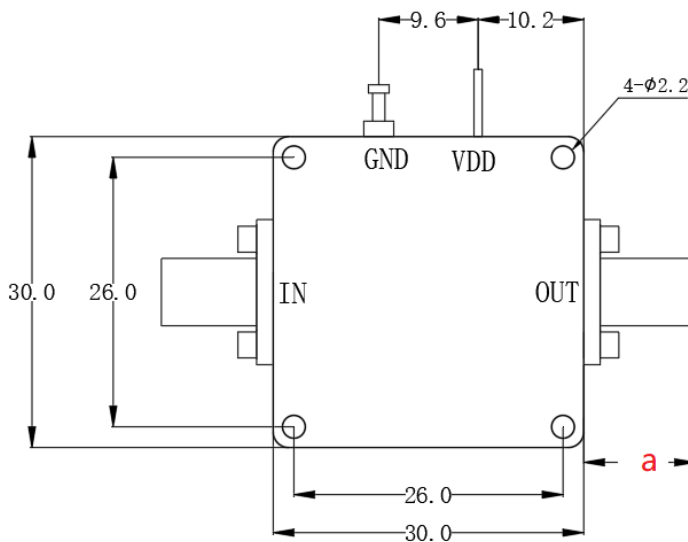

In millimetres

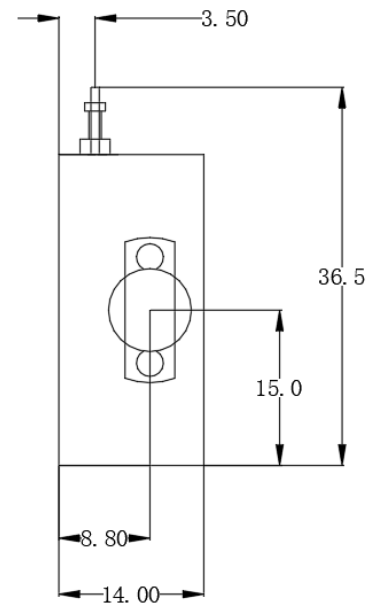

	<26.5GHz	<40GHz	<50GHz	<67GHz
Connector	SMA	2.92mm	2.4mm	1.85mm
Length of a	9.4mm	9.5mm	10.8mm	11.3mm

Note: Female Default. Contact with us for other types.

